



## Lifting modules Solid

Max. lifting force 4,000 N and 6,000 N, stroke from 200 to 400 mm  
 manual-hydraulic version



### Advantages

- Lifting force up to 6,000 N
- Displacement with low friction is also given with high torque load
- High load by roller guiding element with high section modulus
- Sturdy and tough
- Compact design
- Safe and precise handling
- Checked in compliance with DIN EN 1570 with quadruple static overload
- Better working with lower load
- Integrated stop for pedal

### Application

Lifting modules for high demands on performance and service life in the industrial assembly.

### Principal use

- Ergonomic design of working places
- Industrial production plants
- Automotive industry
- Assembly of car seats
- Assembly of drive components, axes and cardan shafts
- Assembly of compressors, hydraulic components and pumps
- Assembly of turbines, motors and gear boxes
- Applications with frequent load changes

### Fixing and installation

For fixing of *modulog* modules or other components of the user at the top plate, the lifting module has an interface 140 x 140 and 200 x 200.

For fixing of *modulog* modules at the bottom plate, the lifting module has an interface 200 x 200. This plate can also be used to fix the lifting module on a flat level floor. For fixing, screws M10 of property class 10.9 as well as heavy-duty plugs are to be used.

For increased stability, a base plate, which can be mounted to the bottom plate, is available as accessory. Fixing on the floor is made by means of the base plate.

### Description

The lifting module has an integrated roller guiding element. This allows a backlash-free guiding system with very good smooth running and the introduction of high moments into the lifting module.

The guiding system is lifetime lubricated. To obtain high robustness, all components are made of high-quality materials. Characteristic are applications with indifferent, dynamically swelling rotating motions and shock motions.

### Material

All essential elements are made of steel to obtain a high robustness.

### Variants

Drive variants with brushless electric motor 48 VDC or hydraulic cylinder can be realised on request as per customer's specifications. Service life and lifting speed is perfect for cycle-related assemblies.

### *modulog*

#### Lifting module

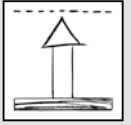

Part no. 8926-0X-X0-H

#### Technical data

Max. lifting force: 4,000 N; 6,000 N  
 Max. bending moment: 1,000 Nm  
 Stroke: 200 to 400 mm

#### Operations

- Pedal



#### Combinable with the modules

- Rotating modules – horizontal axis  
 DMH 200 as per data sheet M 1.101,  
 DMHe 200 as per data sheet M 1.201



- Tilting modules  
 KMB 100 as per data sheet M 2.101  
 KME 100 as per data sheet M 2.201



- Rotating modules – vertical axis  
 DMV 600 as per data sheet M 1.301,  
 DMVe 600 as per data sheet M 1.201



- Cart modules  
 WMS as per data sheet M 5.101



- Floor modules  
 FMS as per data sheet M 6.101



#### *modulog* interfaces

- Top plate: 140 x 140 – M10  
 200 x 200 – Ø 10.5 mm
- Bottom plate: 200 x 200 – Ø 10.5 mm

#### Accessories

- Base and adaptor plates  
 as per data sheet M 8.100 and M 8.110
- Table plates  
 as per data sheet M 8.130

## Manual-hydraulic version operation with foot pedal



### Description

The stroke movement is obtained by a manual-hydraulic lifting drive with single-lever actuation, with oil being pumped by means of a piston pump into a plunger cylinder.

During retraction, the oil returns due to the weight of the load from the cylinder back to the reservoir. A defined speed control is effected.

The manual-hydraulic version is particularly sturdy and durable. This variant meets high safety demands and withstands jerking and knocking loads in applications.

### Operation

To lift the load, the foot pedal has to be depressed by approx. 40° several times. The pedal returns to its off-position by means of a return spring.

To lower the load, the foot pedal has to be moved upwards by approx. 10°.

### Code for part numbers

Part no. **8926-0X-X0-H**

### Maximum lifting force

**4** = 4,000 N  
**6** = 6,000 N

### Stroke

**2** = 200 mm  
**3** = 300 mm  
**4** = 400 mm

### Dimensions

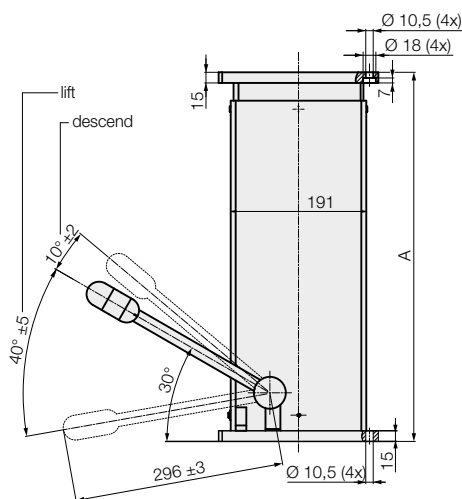

### Technical data

Stroke [mm]	A [mm]	A + stroke [mm]	Weight [kg]
200	420	620	56
300	520	820	64
400	620	1,020	73

Lifting force [N]	Pump strokes per 100 mm	Descent speed [mm/s]
4,000	7	approx. 22
6,000	9	approx. 22

### Maximum lifting force and maximum admissible torque load

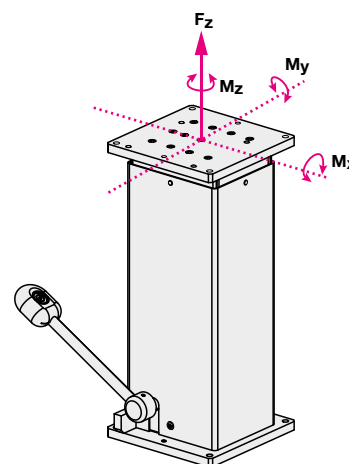

### Maximum lifting force Fz:

Alternatively 4,000 N or 6,000 N

### Maximum torque load:

**Total M<sub>x/y</sub>:** 1,000 Nm  
**M<sub>z</sub>:** 1,000 Nm

### Important notes!

To descend the lifting module, a minimum load of approx. 200 N is required.

The lifting module must only be pressure loaded. The centre of gravity should be within the traverse of the fixing screws. If the centre of gravity is outside, the dowelled joint with the floor has to be dimensioned correspondingly. In such cases it is recommended to use a larger base plate.

In case of eccentric load of more than 250 mm, the column cannot descend automatically because of too high friction forces.

The lifting module is designed for applications within closed rooms.

The hydro-manual lifting drive can not be operated with synchronization control.

In the case of eccentric loads, it is recommended to compensate these by counterweights. In off-position, the indicated maximum torques may occur.

The forces and torques have to be considered by the operator. **During the lifting motion, only 50 % of the maximum values are admitted.**

### Accessories

Base plate for increased stability as per data sheet M 8.100