



## Lifting Modules Shop-Floor Telescope

Max. lifting force 1,000 and 2,000 N, stroke from 300 to 1,000 mm, manual-hydraulic and electro-mechanical version



### Advantages

- Low basic height
- Large strokes
- Simple and intuitive operation
- Working in ergonomically optimum height
- Sturdy industrial design
- Increase of quality in manufacturing and assembly processes
- Short amortisation time
- Increase of assembly throughput and productivity
- High level of safety against static overloads
- Checked in compliance with DIN EN 1570 with quadruple static overload

### Application

Lifting module for workshop applications in the industry.

### Principal use

- Industrial assembly working places
- Height adjustment of assembly working places in workshops
- Service
- Assembly fixtures
- Adjusting systems in supply processes of mid-sized objects
- Handling systems for product packing and transfer

### Fixing and installation

For fixing of *modulog* modules or other components of the user at the top plate, the lifting module has an interface 140 x 140.

For fixing of *modulog* modules at the bottom plate, the lifting module has an interface 200 x 200. This plate can also be used to fix the lifting module on a flat level floor. For fixing, 4 screws M10 of property class 10.9 as well as heavy-duty plugs are to be used.

For increased stability, a base plate, which can be mounted to the bottom plate, is available as accessory. Fixing on the floor is made by means of the base plate.

### Description

The lifting module Shop-Floor Teleskop is particularly suitable for lifting and lowering assembly fixtures, working tables and demonstration objects in industrial applications as well as for medical treatment equipments in medical applications.

In general, lifting modules are used as a base unit of devices for controlled lifting and lowering of loads or for height adjustment only. This version excels particularly by the low base height and the very high strokes.

### Material

Lifting profile: aluminium, naturally anodised  
 Top and bottom plate: aluminium, black anodised

### modulog

#### Lifting module

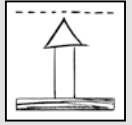

Part no. 89180XX0X

#### Technical data

Max. lifting force: 1.000, 2.000 N  
 Max. bending moment: 500 Nm  
 Stroke: 300 to 1,000 mm

#### Operations

- Foot pedal
- Foot switch
- Hand panel



#### Combinable with the modules

- Rotating modules – horizontal axis  
 DMH 200 as per data sheet M 1.101  
 DMHe 200 as per data sheet M 1.201



- Tilting modules  
 KMB 100 as per data sheet M 2.101  
 KME 100 as per data sheet M 2.201



- Rotating modules – vertical axis  
 DMV 600 as per data sheet M 1.301  
 DMVe 600 as per data sheet M 1.201



- Cart modules  
 WMS  
 as per data sheet M 5.101



- Floor modules  
 FMS as per data sheet M 6.101  
 FMD as per data sheet M 6.201



#### modulog interfaces

- Top plate: 140 x 140 - Ø 10.5 mm
- Bottom plate: 200 x 200 - Ø 10.5 mm

#### Accessories

- Electronic control modules for 1, 2, 3 or 4 lifting modules as per data sheet M 8.200
- Control modules with battery holder as per data sheet M 8.201
- Electrical operating elements, lines and connectors as per data sheet M 8.203
- Base and adaptor plates as per data sheet M 8.100 and M 8.110
- Table plates as per data sheet M 8.130 and M 8.131

## Manual-hydraulic version operation with foot pedal



### Description

The stroke movement is obtained by a hydraulic linear unit with single-lever actuation with oil being pumped by means of a piston pump into a plunger cylinder.

During retraction, the oil returns due to the weight of the load from the cylinder back to the reservoir. A defined speed reduction is effected, independent of the load.

The manual-hydraulic variant is particularly sturdy and durable. This variant meets high safety demands and withstands jerking and knocking loads in applications.

According to the application, 2 different force levels can be selected. The number of pump strokes depends on the force level.

### Code for part numbers

**Part no.** 89180 X X0H

### Maximum lifting force

- 1** = 1,000 N
- 2** = 2,000 N

### Stroke

- 3** = 300 mm
- 4** = 400 mm
- 6** = 600 mm
- 8** = 800 mm
- 10** = 1,000 mm

### Dimensions

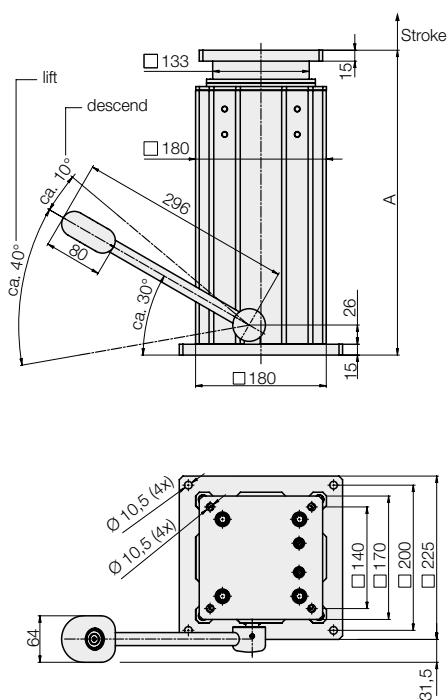

### Operation

To lift the load, the foot pedal has to be depressed by approx. 40° several times. The pedal returns to its off-position by means of a return spring.

To lower the load, the foot pedal has to be moved upwards by approx. 10°.

### Maximum lifting force and maximum admissible torque load

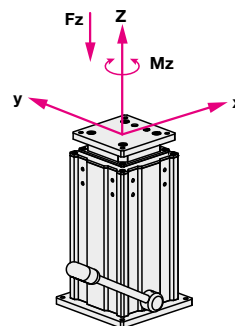

Stroke [mm]	A [mm]	A + stroke [mm]	Weight [kg]
300	420	720	15
400	470	870	20
600	570	1,170	25
800	670	1,470	30
1,000	770	1,770	35

Lifting force [N]	Pump strokes per 100 mm	Descent speed [mm/s]
1,000	2.2	approx. 90
2,000	3.5	approx. 60

### Accessories

Base plate for increased stability as per data sheet M 8.100

### Important notes!

To descend the lifting module, a minimum load of approx. 200 N is required.

The lifting module must only be pressure loaded. The centre of gravity should be within the traverse of the fixing screws. If the centre of gravity is outside, the dowelled joint with the floor has to be dimensioned correspondingly. In such cases it is recommended to use a larger base plate.

In case of eccentric load of more than 250 mm, the column cannot descend automatically because of too high friction forces.

The lifting module is designed for applications within closed rooms.

The hydro-manual lifting drive cannot be operated with synchronization control.

### Maximum lifting force Fz

Alternatively 1,000 N, 2,000 N

### Maximum torque load:

**Total M<sub>x/y</sub>:** 500 Nm  
**M<sub>z</sub>:** 300 Nm

In the case of eccentric loads, it is recommended to compensate these by counterweights. In off-position, the indicated maximum torques may occur.

The forces and torques have to be considered by the operator. **During the lifting motion, only 50 % of the maximum values are admitted.**

# Electro-mechanical version

## Operation with foot switch or hand panel



### Description

The lifting motion is generated by an electric motor with a spindle lifting gear.

The electrically operated variant is particularly suitable for positioning and adjusting tasks of working tables as well as for material supply and transport.

They excel by a smooth running.

### Operation

Lifting and lowering with hand panels or foot switches as per data sheet M 8.203 is triggered by touch control. After release of the push-button, the motion will be immediately stopped.

The hand panel with memory function allows to store 5 positions, which can be approached via corresponding position push-buttons. (for detailed description see data sheet M 8.203)

### Synchronization

Up to 4 lifting modules can be operated with synchronization control by a corresponding control module.

For example, complete lifting platforms can be designed.

**For operation with synchronization control, only lifting modules with code letter G are suitable.**

Please also pay attention to the instructions for the operation of lifting modules in synchronism on data sheet M 4.005.

Control units with synchronization control for 2, 3, or 4 lifting modules are available.

### Code for part numbers

**Part no.** 89180 X X0 X

### Maximum lifting force

- 1** = 1,000 N
- 2** = 2,000 N

### Stroke

- 3** = 300 mm
- 4** = 400 mm
- 6** = 600 mm
- 8** = 800 mm
- 10** = 1,000 mm

### Electronics

- E** = integrated stroke end disconnection (not suitable for synchronization control) with coiled connecting cable, 1.5 m
- G** = with incremental stroke measuring system (suitable for synchronization control) with smooth connecting cable, 2.5 m
- I** = with incremental stroke measuring system (suitable for memory function) with smooth connecting cable, 2.5 m
- B** = with incremental stroke measuring system (suitable for memory function and battery mode) with smooth connecting cable, 0.3 m

In case of the version with a lifting force of 1,000 N, the electronic version **G** is identical with the version **I**.

Delivered will be always version **G**, which is suitable for memory function as well as for synchronization.

### Dimensions

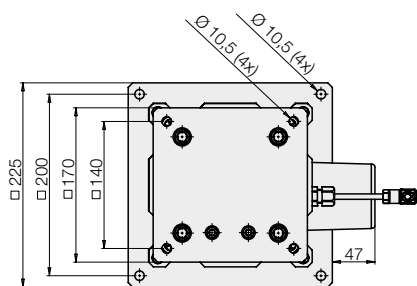
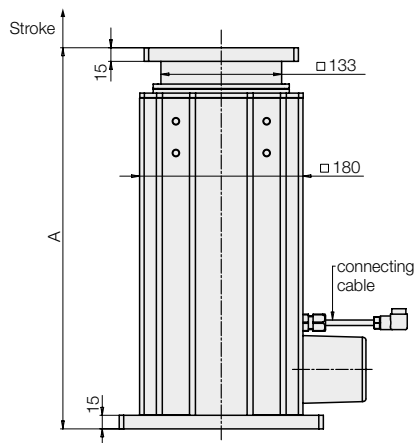

### Technical data

Electric connection	Connector
Duty cycle	15 % ED
Code class	IP 54
Control voltage	24 V DC

### Variant E, I and B

Lifting force	Lifting speed (load-dependent)	Current consumption (load dependent)
[N]	[mm/s]	[A]
1,000	32 ... 28	5
2,000	18 ... 16	6

### Variant G

Lifting force	Lifting speed (load-dependent)	Current consumption (load dependent)
[N]	[mm/s]	[A]
2,000	16 ... 12	4.5

### Accessories

Base plate for increased stability as per data sheet M 8.100

### Delivery

The lifting modules are delivered ready for connection. The connecting cable from the lifting module to the control module is included in the delivery. Operating elements as well as control modules and mains cables can be ordered separately as an accessory.

### Electrical accessories required for a functional system:

- Control module as per data sheet M 8.200 or
- Control module with battery holder as per data sheet M 8.201
- Hand panels, foot switch and mains cable as per data sheet M 8.203

### Important notes!

- Maximum admissible torque load as per manual-hydraulic version (see page 2).
- The maximum pull force of the electro-mechanical version is 80 % of the push force!